



NIBCO INC.  
500 SIMPSON AVENUE  
P.O. BOX 1167  
ELKHART, IN 46515-1167  
(219) 295-3000  
FAX (219) 295-3307

## INSTALLATION AND MAINTENANCE

### GUIDELINES

FOR

3-PIECE BRONZE BALL VALVES

**\*\*\* CAUTION \*\*\***

ONLY QUALIFIED PERSONNEL SHOULD UNDERTAKE THE PROCEDURES OUTLINED BELOW. NIBCO, INC., ITS AGENTS, REPRESENTATIVES AND EMPLOYEES ASSUMES NO LIABILITY FOR THE USE OF THESE PROCEDURES. THESE PROCEDURES ARE OFFERED AS SUGGESTIONS ONLY.

## I. INSTALLATION

- A. Standard Series 590 and 595 NIBCO ball valves may be installed for pressure or vacuum service in either direction.
- B. For threaded valves, care must be taken to exclude pipe sealants from the valve cavity.
- C. For solder valves:
  1. Fit valve into place between the two pieces of tubing after cleaning and fluxing.
  2. Remove top two body bolts, loosen the other two.
  3. Carefully remove center section without altering the radial position of the seat ring or damaging O-ring seals.
  4. Attach end pieces to tubing by soldering or brazing in a workman-like manner.
  5. Allow end pieces to cool.
  6. Carefully install center section without altering the radial location of seat rings or damaging O-ring seals.
  7. Tighten body bolts evenly to the torques listed in Table 1.

TABLE 1

<u>VALVE</u>	<u>TORQUE (FT.-LBS.)</u>
595, 1/4"	5- 6
595, 3/8"	5- 6
595, 1/2"	5- 6
595, 3/4"	8-10
590, 1-1/4"	10-12
595, 1"	10-12
590, 1-1/2"	12-15
595, 1-1/4"	12-15
590, 2"	12-15
595, 1-1/2"	12-15
590, 2-1/2"	20-25
595, 2"	20-25
590, 3"	20-30
595, 2-1/2"	20-30

#### D. CAUTION

1. Care must be taken to avoid scratching the machined sealing surface of the end piece.
2. Over tightening of body bolts could result in damage to end piece.
3. Excessive temperature or uneven heating could result in damage to end piece.
4. Changing the radial location of the seat rings could result in leakage through the seat.

### II. OPERATION

- A. Valve is operated by rotating the handle clockwise a quarter-turn to close or counter-clockwise a quarter-turn to open. The handle is in alignment with the opening through the ball.
- B. Valve can be used for throttling, provided the flow rate is not high enough to create cavitation.
- C. Valve will provide bubble-tight seal in closed position when used in accordance with pressure/temperature chart published by NIBCO.
- D. Media which can solidify, crystallize or polymerize should not be allowed to stand in ball valve cavities.
- E. Liquids trapped around the outside of the ball should not be subjected to excessive increases in temperature.

### III. MAINTENANCE

If seepage is noted around the stem, tighten packing nut (Item 3, exploded view) to the torque specified in Table 2.

TABLE 2

<u>VALVE</u>	<u>TORQUE</u> <u>(FT.-LBS.)</u>
595, 1/4"	4- 6
595, 3/8"	4- 6
595, 1/2"	4- 6

TABLE 2 (CON'T)

595, 3/4"	12-15
590, 1-1/4"	12-15
595, 1"	12-15
590, 1-1/2"	15-20
595, 1-1/4"	15-20
590, 2"	15-20
595, 1-1/2"	15-20
590, 2-1/2"	15-20
595, 2"	15-20
590, 3"	45-55
595, 2-1/2"	45-55

#### **IV. REBUILDING**

A standard repair kit may be ordered, consisting of TFE seats, reinforced TFE thrust washer, TFE packing and fluorocarbon O-ring seals.

- A. Persons involved in removal and disassembly of valve should wear appropriate protective equipment such as safety glasses, gloves, etc.
- B. Relieve line pressure.
- C. Open valve halfway to remove any fluid trapped in cavity around ball.
- D. Place valve in open position, loosen body bolts, remove two body bolts and nuts and lift out center section.
- E. Rotate handle to closed position, remove old seats, body seals and ball.
- F. Remove handle nut, handle, packing nut from body.
- G. Push stem into body cavity and remove.
- H. Remove thrust washer from stem and packing from body. (Leave grounding washer in valve body.
- I. Check and clean all sealing surfaces.
- J. Place thrust washer on stem and install through body cavity.

K. Install ball, seats and O-rings in body. With ball in open position, carefully place body assembly between pipe ends.

**CAUTION:** DO NOT SCRATCH BODY SEALS OR DAMAGE O-RINGS WHEN PLACING VALVE BODY BETWEEN PIPE ENDS.

L. Replace body bolts and nuts then tighten evenly to the torque value specified in Table 1.

M. Make sure that grounding washer is still in place, then install packing over stem into packing cavity of body. Thread packing nut into packing cavity to the torque specified in Table 2.

N. Place handle and handle nut on stem and tighten until handle is snug.

**WARNING:** DO NOT SOLDER OR BRAZE WITH FLUID TRAPPED IN THE CAVITY AROUND THE BALL. THERMAL EXPANSION OF THIS FLUID COULD PRODUCE EXCESSIVE INTERNAL PRESSURE WHICH WILL DAMAGE SEAT OR BODY MATERIALS.

DET. NUMBER	ITEM DESCRIPTION	REQD.
1	HANDLE NUT	1
2	HANDLE	1
3	PACK GLAND	1
4	PACKING	1
5	GROUNDING WASHER	1
6	BODY BOLT	4
7	BODY END	2
8	O-RING SEAL	2
9	SEAT RING	2
10	BALL	1
11	BODY	1
12	THRUST WASHER	1
13	STEM	1
14	BODY NUT	4

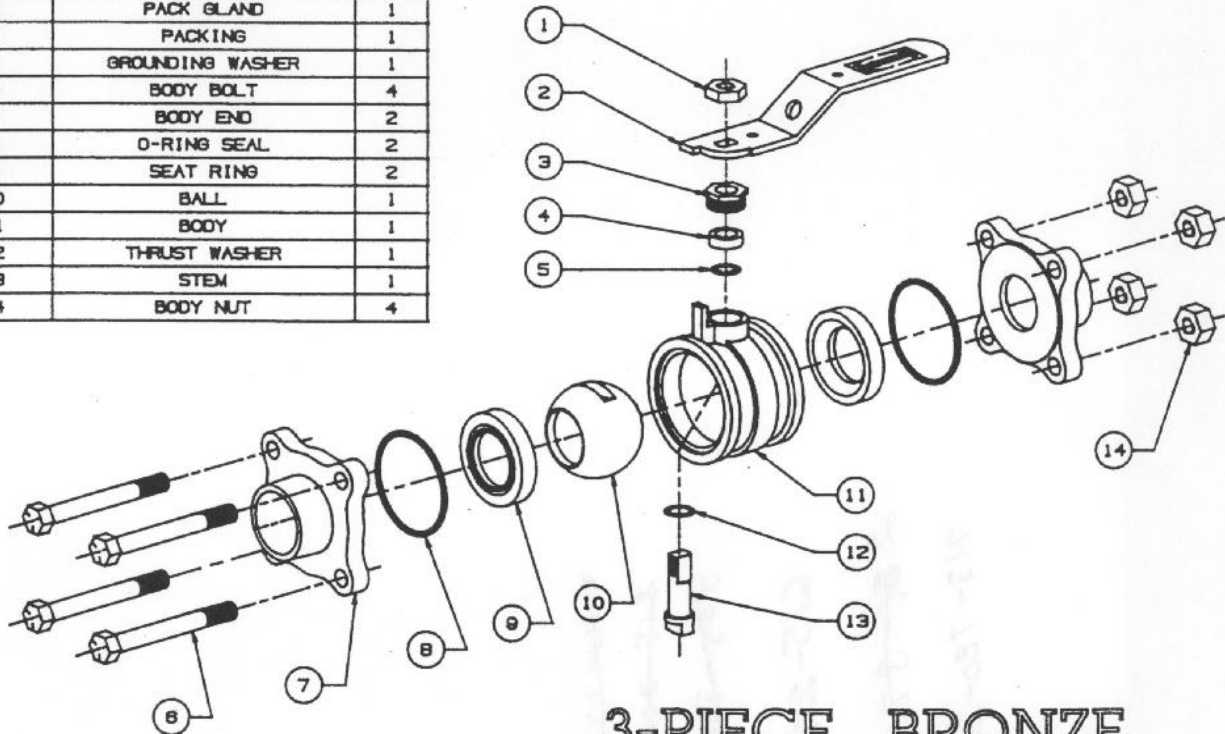

**3-PIECE BRONZE  
BALL VALVE**